

SOWAKAM

SW200 Series

**High Performance
Variable Frequency Drive**

www.sowakam.com



SOWAKAM

High Performance
Variable Frequency Drive



Certified

Satisfies CE certification
Satisfies International
standard: EN61800-3

Easy to use

Support parameter copy
Support panel external
reference

Stable and reliable

Spray UV paint
Strong environmental adaptability,
stable and reliable

Strong function

Support synchronous
asynchronous motor drive
Support terminal PNP/NPN
function

Wide voltage range

Single phase 200-240V
Three phase 200-240V
Three phase 380-480V
Single phase 220V to
three phase 380V

Multiple control methods

V/F
SVC
MPPT



SW200 Advantage

Easy to use

Panel

Support parameter copy
Support panel external reference



Stable and reliable

UV paint

Automatic spraying of UV paint, uniform coverage, smoother and more delicate

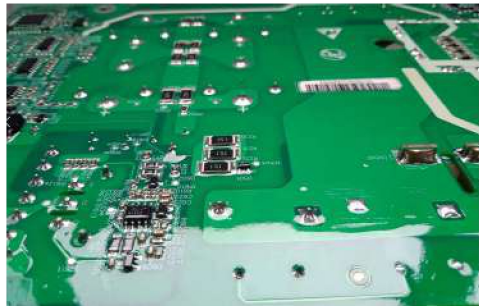

Strong function

Synchronous asynchronous motor integrated

Compatible with synchronous machine and asynchronous machine, energy-saving transformation is effortless



Synchronous motor



asynchronous motor



MOTOR TYPE :

CONTROL MODE :

Synchronous motor

SVC, VF, MPPT

asynchronous motor

SVC, VF, MPPT

NPN/PNP Function

Select NPN/PNP function by DIP switch

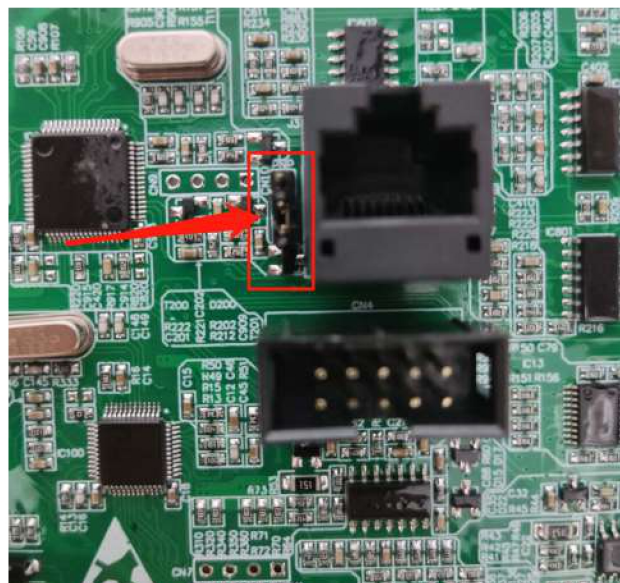

Wide voltage range

Wide area of use

- Support single phase 200-240V AC
- Support three-phase 200-240V AC
- Support three-phase 380-480V AC
- Support single phase 220V input, three phase 380V output
- Can be used at -20% ~ +10% of the above voltage

Comply with most national grid standards

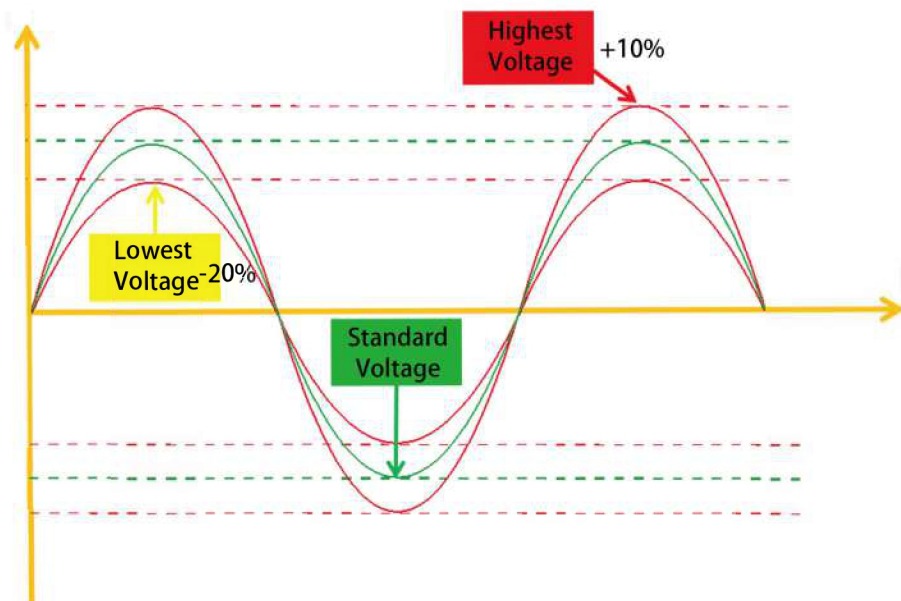

Multiple control methods

SVC V/F MPPT

MPPT

- Comprehensive voltage level Support single phase/three phase 220V, and three phase 380V solar water pump VFD
- Easy to use Simply connect the photovoltaic panel to the VFD, few parameters need to be set, and the PV pump can be automatically started after power-on

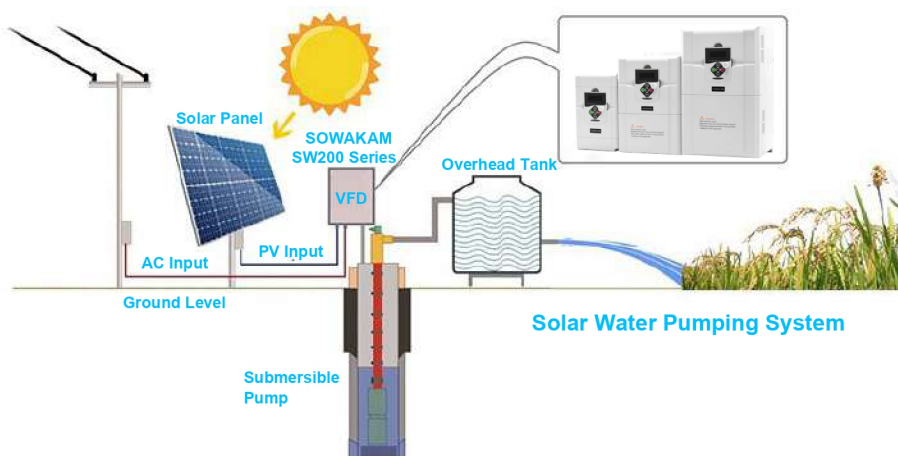



Appearance and Installation Size

0.4-7.5KW Shape

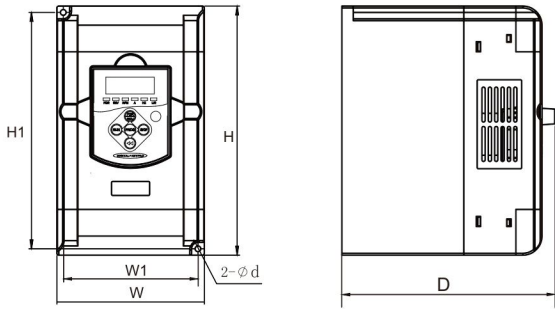

11-15KW Shape

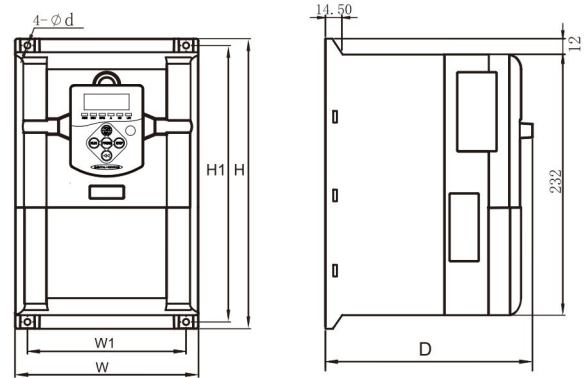

18.5-30KW Shape

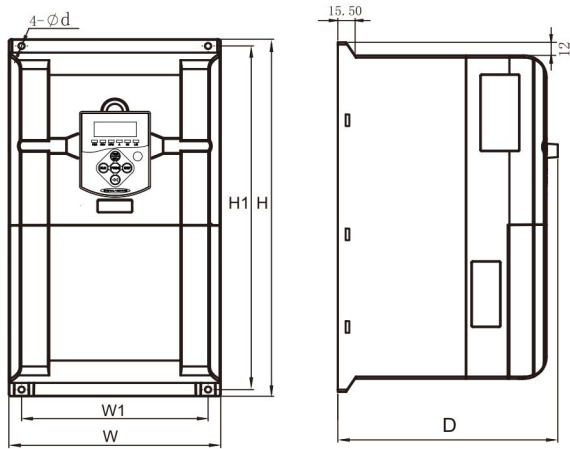

37-500KW Shape

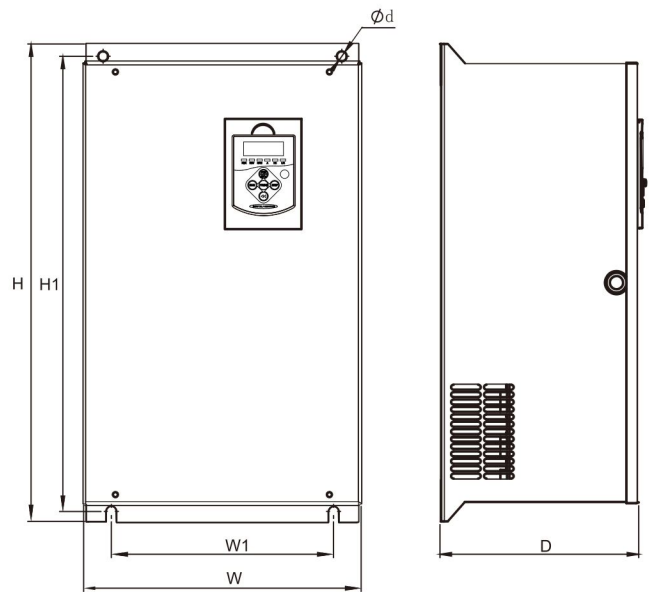

Product Mode	Machine Dimensions			Installation dimensions		
	H	W	D	H1	W1	d
0.4-7.5KW	196	116	168	186	106	2*4.5
11-15KW	256	162	183	244	140	4*5.4
18.5-30KW	320	184	198	308	162	4*5.4
37-45KW	430	288	223	414	170	7
55-75KW	580	337	242	553	270	12

Product Mode	Machine Dimensions			Installation dimensions		
	H	W	D	H1	W1	d
90-110KW	650	379	242	623	270	12
132-160KW	700	410	350	678	280	14
185-220KW	888	570	390	850	380	12
250-315KW	1050	665	392	1012	515	14
355-500KW	1100	824	417	1060	600	14



SW200- Specification

Name		Specification
Input Power	Voltage	1PH/3PH 200~240V -20%~+10%; 3PH 380~480V -20%~+10%;
	Frequency	48-62HZ;
	Max Unbalance	3%;
Output Power	Output Voltage	3PH 0~240V/0~480V;
	Output Frequency	Vector control;V/F:0-600Hz;
Main Control Function	Control Mode	V/F,Vector control; MPPT
	Start Torque	0.5Hz 150%;
	Overload Capacity	150% Rated output current(60s) , 200% Rated output current(1s);
	Carrier Frequency	V/F: 2K~16kHz, Vector: 2K~10KHz;
	Speed Setting Resolution	Digital: 0.001Hz; Analog: 0.5% of Max Operation Frequency;
	Open Loop Speed Control Accuracy	30~4000rpm:Error±8rpm;
	Control Command Source	Operate Panel; Digital Terminal; Communication;
	Set Frequency Source	Panel; Analog; Pulse; Communication;
Acceleration and Deceleration time	4 Groups Acceleration and Deceleration time is 0.05-3600.00S;	
Basic Function	Torque open loop control, Motor self-learn, Motor Pre-excitation, Motor Rotation Compensation, Automatic Load Compensation, Automatic Voltage Stabilizing Function, Multi-Point V/F curve, Acceleration and Deceleration Curve, DC Braking, AC Braking, Rotation Speed Limited, Current Limited, Torque Limited, Frequency Tracking Start, Auto Reset Restart, JOG Control, External Control of Multistage Speed, Mechanical Braking, UP/DOWN Function, High speed pulse input and output function, Built in PID Controller;	
Protect Function	Phase Loss Protection of Power Supply, Short-voltage Protection, Over-voltage Protection, Overcurrent Protection, Over-load Protection, Phase Loss Protection of Output, Output short circuit Protection, Output Grounded Protection, Signal Disconnection, AMA Fail, CPU Fault, Button Inhibit, Copy Failure, LCP Communication Error, Parameter Read Only, Value Out of Range, Not ecutable in Running;	
IO Panel Control Terminal	Input Terminal	6 digital input terminals; One channel (X3) supports high-speed pulse input up to 100KHZ; 2 analog input terminals (0-10V voltage signal, 0-20mA current signal);
	Output Terminal	2 analog output terminals, support 0-10V voltage output or 0-20mA current output.(Only 1 channel output is supported below 30KW,Default: Voltage variable 0-10V) 2 relay output terminals (KA/KB is normally open, KA/KC is normally closed)(Only 1 channel relay output terminal is supported below 30KW)
	Power Supply Terminals	1 Group 10V Power Supply Terminal, Max Output Current: 10mA; 1Group 24VPower Supply Terminal, Max Output Current: 100mA;
	Communication Terminals	Max Baud Rate 38400bit/s
Panel	5-Digit 8-Segment LED display	Display the frequency/alarm/Status and other information
	Monitoring Function	Set Value, Output Frequency, Feedback Value, Output Current, DC Bus Voltage, Output Voltage, Output Power, Output Terminals State, Input Terminals State, Input Analog Value, Analog B Output Value, History 1-3 Fault Records and Accumulated Working Hours;
	Indicator Light	Indicator Light FOR, REV, RPM, Hz, A, L/R display various states of Inverter;
Environment	Protection Level	IP20;
	Operation Temperature	-10°C~40°C, Over 40°C need bigger capacity inverter;
	Operation Humidity	5%-85%(95% No drops of water);
	Vibration	< 5.9m/S ² (0.6g);
	Highest altitude	1000m, Over 1000m need bigger power inverter;
Length of Motor Wire line	Shielding wire: 50m; Unshielding wire: 10m;	
Others	DC reactor	NO;
	Braking Unit	Built-in (built-in below 30KW, external for other power segments).



SW200- Specification

Power	Input voltage	Input current (A)	Output current (A)
0.40	1×200-240V	6.5	2.3
0.75	1×200-240V	11.3	4.0
1.5	1×200-240V	18.5	7.0
2.2	1×200-240V	23.9	11
3.0	1×200-240V	28.1	13
4.0	1×200-240V	36.4	17
5.5	1×200-240V	49	23
7.5	1×200-240V	62	32
11	3×200-240V	84	45
15	3×200-240V	93	61
0.4	3×200-240V	3.6	2.5
0.75	3×200-240V	6.5	5.0
1.5	3×200-240V	11	7.5
2.2	3×200-240V	17.7	11
3.0	3×200-240V	23	13
4.0	3×200-240V	27	17
5.5	3×200-240V	35	25
7.5	3×200-240V	43	32
11	3×200-240V	61	45
15	3×200-240V	73	61
0.4	3×380-440V	2.4	1.2
	3×440-480V	2.1	1.7
0.75	3×380-440V	3.7	2.1
	3×440-480V	3.2	2.1
1.5	3×380-440V	6.4	4
	3×440-480V	5.5	3.6
2.2	3×380-440V	8.9	5.6
	3×440-480V	7.7	5.1
3.0	3×380-440V	13.4	7.3
	3×440-480V	11.8	6.8
4.0	3×380-440V	15.8	9.8
	3×440-480V	13.6	9
5.5	3×380-440V	21.3	13.3
	3×440-480V	18.4	12.1
7.5	3×380-440V	28.3	17.7
	3×440-480V	24.4	16.1

Power	Input voltage	Input current (A)	Output current (A)
11	3×380-440V	35.9	25
	3×440-480V	31.4	22.7
15	3×380-440V	43.4	32
	3×440-480V	38.8	29.1
18.5	3×380-440V	51	38
	3×440-480V	46	35
22	3×380-440V	61	45
	3×440-480V	55	41
30	3×380-440V	72	61
	3×440-480V	64	52
37	3×380-440V	74	75
	3×440-480V	67	68
45	3×380-440V	86	91
	3×440-480V	80	82
55	3×380-440V	110	112
	3×440-480V	108	110
75	3×380-440V	148	150
	3×440-480V	135	140
90	3×380-440V	175	180
	3×440-480V	154	160
110	3×380-440V	206	215
	3×440-480V	183	190
132	3×380-440V	251	260
	3×440-480V	231	240
160	3×380-440V	304	315
	3×440-480V	291	302
185	3×380-440V	350	365
	3×440-480V	320	335
200	3×380-440V	381	395
	3×440-480V	348	361
220	3×380-440V	420	435
	3×440-480V	383	398
250	3×380-440V	472	480
	3×440-480V	436	443
280	3×380-440V	525	540
	3×440-480V	475	490
315	3×380-440V	590	605
	3×440-480V	531	540
355	3×380-440V	647	660
	3×440-480V	580	590
400	3×380-440V	718	745
	3×440-480V	653	678
450	3×380-440V	860	883
	3×440-480V	760	785
500	3×380-440V	920	950
	3×440-480V	835	860

SW200- Control loop wiring diagram

